

DM74LS393 Dual 4-Bit Binary Counter

General Description

Each of these monolithic circuits contains eight master-slave flip-flops and additional gating to implement two individual four-bit counters in a single package. The 'LS393 comprises two independent four-bit binary counters each having a clear and a clock input. N-bit binary counters can be implemented with each package providing the capability of divide-by-256. The LS393 has parallel outputs from each counter stage so that any submultiple of the input count frequency is available for system-timing signals.

Features

- Dual version of the popular 'LS93
- 'LS393 dual 4-bit binary counter with individual clocks
- Direct clear for each 4-bit counter
- Dual 4-bit versions can significantly improve system densities by reducing counter package count by 50%
- Typical maximum count frequency 35 MHz
- Buffered outputs reduce possibility of collector commutation

Connection Diagram

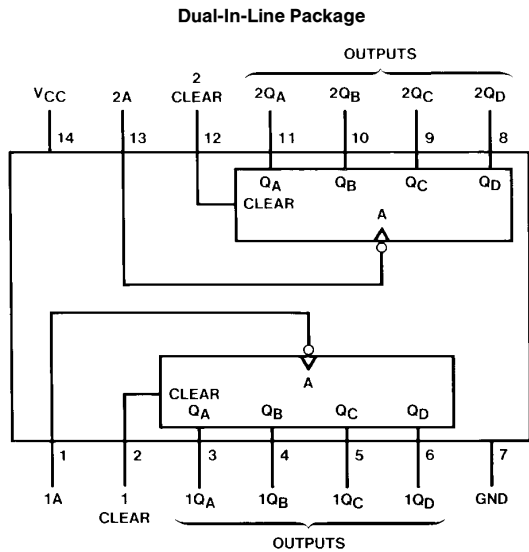

TL/F/6434-1

Order Number DM74LS393M or DM74LS393N
See NS Package Number M14A or N14A

Function Table

Count	Count Sequence (Each Counter)			
	Q _D	Q _C	Q _B	Q _A
0	L	L	L	L
1	L	L	L	H
2	L	L	H	L
3	L	L	H	H
4	L	H	L	L
5	L	H	L	H
6	L	H	H	L
7	L	H	H	H
8	H	L	L	L
9	H	L	L	H
10	H	L	H	L
11	H	L	H	H
12	H	H	L	L
13	H	H	L	H
14	H	H	H	L
15	H	H	H	H

H = High Logic Level

L = Low Logic Level

Absolute Maximum Ratings (Note)

If Military/Aerospace specified devices are required, please contact the National Semiconductor Sales Office/Distributors for availability and specifications.

Supply Voltage	7V
Input Voltage	
Clear	7V
A	5.5V
Operating Free Air Temperature Range	
DM74LS	0°C to +70°C
Storage Temperature Range	-65°C to +150°C

Note: The "Absolute Maximum Ratings" are those values beyond which the safety of the device cannot be guaranteed. The device should not be operated at these limits. The parametric values defined in the "Electrical Characteristics" table are not guaranteed at the absolute maximum ratings. The "Recommended Operating Conditions" table will define the conditions for actual device operation.

Recommended Operating Conditions

Symbol	Parameter	DM74LS393			Units
		Min	Nom	Max	
V _{CC}	Supply Voltage	4.75	5	5.25	V
V _{IH}	High Level Input Voltage	2			V
V _{IL}	Low Level Input Voltage			0.8	V
I _{OH}	High Level Output Current			-0.4	mA
I _{OL}	Low Level Output Current			8	mA
f _{CLK}	Clock Frequency (Note 1)	0		25	MHz
f _{CLK}	Clock Frequency (Note 2)	0		20	MHz
t _w	Pulse Width (Note 7)	A	20		ns
		Clear High	20		
t _{REL}	Clear Release Time (Notes 3 & 7)	25 ↓			ns
T _A	Free Air Operating Temperature	0		70	°C

Electrical Characteristics over recommended operating free air temperature range (unless otherwise noted)

Symbol	Parameter	Conditions	Min	Typ (Note 4)	Max	Units
V _I	Input Clamp Voltage	V _{CC} = Min, I _I = -18 mA			-1.5	V
V _{OH}	High Level Output Voltage	V _{CC} = Min, I _{OH} = Max V _{IL} = Max, V _{IH} = Min	2.7	3.4		V
V _{OL}	Low Level Output Voltage	V _{CC} = Min, I _{OL} = Max V _{IL} = Max, V _{IH} = Min		0.35	0.5	V
		I _{OL} = 4 mA, V _{CC} = Min		0.25	0.4	
I _I	Input Current @ Max Input Voltage	V _{CC} = Max, V _I = 7V	Clear		0.1	mA
		V _{CC} = Max, V _I = 5.5V	A		0.2	
I _{IH}	High Level Input Current	V _{CC} = Max, V _I = 2.7V	Clear		20	μA
			A		40	
I _{IL}	Low Level Input Current	V _{CC} = Max, V _I = 0.4V	Clear		-0.4	mA
			A		-1.6	
I _{OS}	Short Circuit Output Current	V _{CC} = Max (Note 5)	-20		-100	mA
I _{CC}	Supply Current	V _{CC} = Max (Note 6)		15	26	mA

Note 1: C_L = 15 pF, R_L = 2 kΩ, T_A = 25°C and V_{CC} = 5V.

Note 2: C_L = 50 pF, R_L = 2 kΩ, T_A = 25°C and V_{CC} = 5V.

Note 3: The symbol (↓) indicates that the falling edge of the clear pulse is used for reference.

Note 4: All typicals are at V_{CC} = 5V, T_A = 25°C.

Note 5: Not more than one output should be shorted at a time, and the duration should not exceed one second.

Note 6: I_{CC} is measured with all outputs open, both CLEAR inputs grounded following momentary connection to 4.5V, and all other inputs grounded.

Note 7: T_A = 25°C, and V_{CC} = 5V.

Switching Characteristics at $V_{CC} = 5V$ and $T_A = 25^\circ C$ (See Section 1 for Test Waveforms and Output Load)

Symbol	Parameter	From (Input) To (Output)	$R_L = 2\text{ k}\Omega$				Units
			$C_L = 15\text{ pF}$		$C_L = 50\text{ pF}$		
			Min	Max	Min	Max	
f_{MAX}	Maximum Clock Frequency	A to Q_A	25		20		MHz
t_{PLH}	Propagation Delay Time Low to High Level Output	A to Q_A		20		24	ns
t_{PHL}	Propagation Delay Time High to Low Level Output	A to Q_A		20		30	ns
t_{PLH}	Propagation Delay Time Low to High Level Output	A to Q_D		60		87	ns
t_{PHL}	Propagation Delay Time High to Low Level Output	A to Q_D		60		87	ns
t_{PHL}	Propagation Delay Time High to Low Level Output	Clear to Any Q		39		45	ns

Logic Diagram

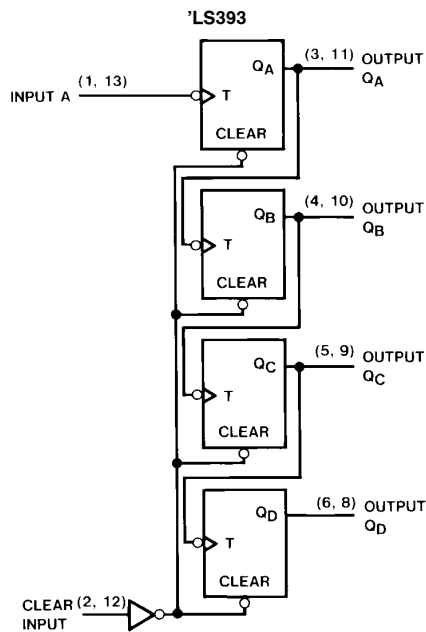

TL/F/6434-2



Physical Dimensions inches (millimeters)

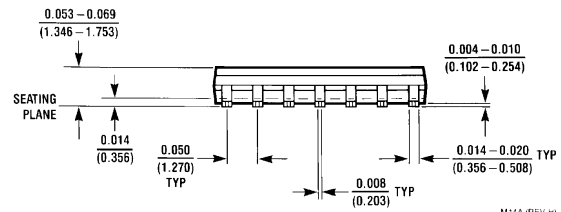
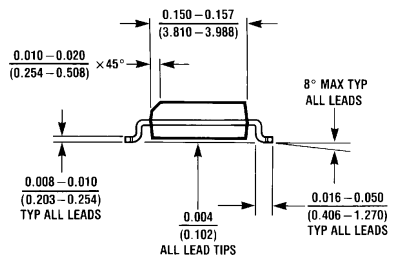
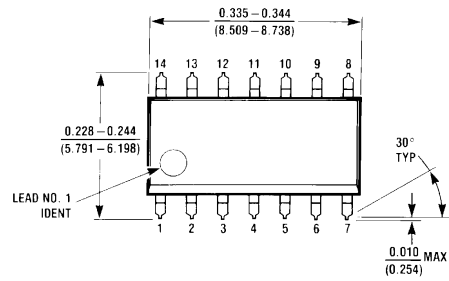

M14A (REV HI)

14-Lead Small Outline Molded Package (M)
Order Number DM74LS393M
NS Package Number M14A

Physical Dimensions inches (millimeters) (Continued)

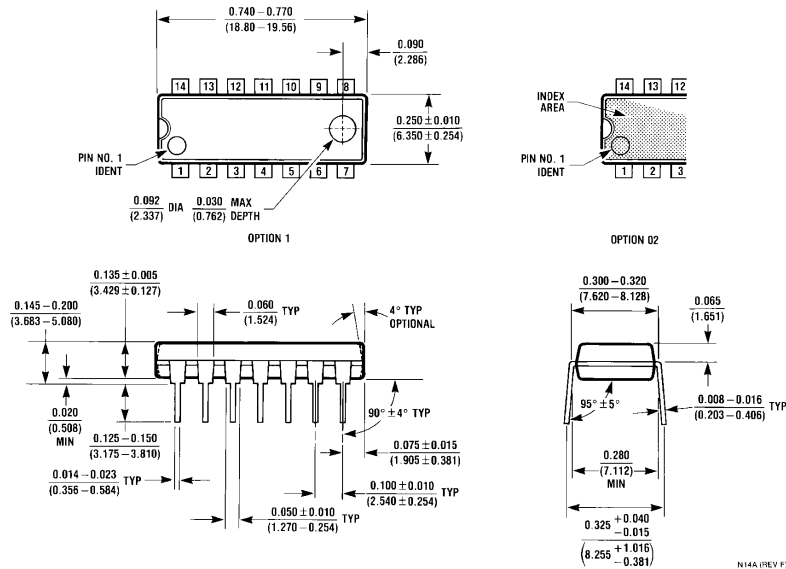

14-Lead Molded Dual-In-Line Package (N)
Order Number DM74LS393N
NS Package Number N14A

LIFE SUPPORT POLICY

NATIONAL'S PRODUCTS ARE NOT AUTHORIZED FOR USE AS CRITICAL COMPONENTS IN LIFE SUPPORT DEVICES OR SYSTEMS WITHOUT THE EXPRESS WRITTEN APPROVAL OF THE PRESIDENT OF NATIONAL SEMICONDUCTOR CORPORATION. As used herein:

1. Life support devices or systems are devices or systems which, (a) are intended for surgical implant into the body, or (b) support or sustain life, and whose failure to perform, when properly used in accordance with instructions for use provided in the labeling, can be reasonably expected to result in a significant injury to the user.
2. A critical component is any component of a life support device or system whose failure to perform can be reasonably expected to cause the failure of the life support device or system, or to affect its safety or effectiveness.



National Semiconductor Corporation
 1111 West Bardin Road
 Arlington, TX 76017
 Tel: 1(800) 272-9959
 Fax: 1(800) 737-7018

National Semiconductor Europe
 Fax: (+49) 0-180-530 85 86
 Email: cnjwge@tevm2.nsc.com
 Deutsch Tel: (+49) 0-180-530 85 85
 English Tel: (+49) 0-180-532 78 32
 Français Tel: (+49) 0-180-532 93 58
 Italiano Tel: (+49) 0-180-534 16 80

National Semiconductor Hong Kong Ltd.
 19th Floor, Straight Block,
 Ocean Centre, 5 Canton Rd.
 Tsimshatsui, Kowloon
 Hong Kong
 Tel: (852) 2737-1600
 Fax: (852) 2736-9960

National Semiconductor Japan Ltd.
 Tel: 81-043-299-2309
 Fax: 81-043-299-2408

National does not assume any responsibility for use of any circuitry described, no circuit patent licenses are implied and National reserves the right at any time without notice to change said circuitry and specifications.